

PORTACOOOL CYCLONE™ OWNER'S MANUAL

PORTACOOOL™

WHEN COMFORT COUNTS™



TABLE OF CONTENTS

READ AND SAVE THESE INSTRUCTIONS

CONTENTS:

QUICK SETUP GUIDE.....	page 2	TROUBLESHOOTING	pages 12-13
PRODUCT OVERVIEW	pages 3-7	TECHNICAL SUPPORT AND WARRANTY	pages 14-15
SAFETY INFORMATION	page 8	EXPLODED VIEWS	pages 16-20
GENERAL OPERATION	pages 9-10	WIRING DIAGRAM	page 21
MAINTENANCE AND STORAGE	page 11	FREQUENTLY ASKED QUESTIONS.....	page 22



STOP

DO NOT RETURN!

For questions or comments, please call Portacool Customer Service at 936-598-5651.

QUICK SET UP

1

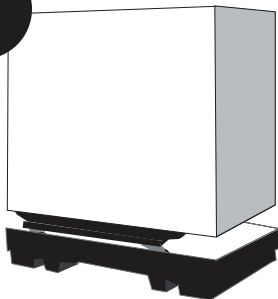

Remove box and pallet

2

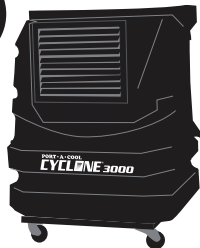

Position product on level surface

3



Fill sump or attach water hose

4



Plug into appropriate outlet

5

For setup, pads should appear wet before starting the fan. Check the water gauge to monitor water level in tank. The water flow valve on each unit is set at max flow. However, ensure the knob is turned completely to the left before use. Turn to the left to increase water flow. Less water is required for cooling in more humid environments.



Models: PAC2KCYC01, PAC2KCYC01A, PACCYC02, PACCYC02A, PACCYC03, PACCYC03A, PACCYC04, PACCYC04A



Models: PACCYC06

Fill the tank, then turn on the pump switch and the fan.

CYCLONE 3000 OVERVIEW

PAC2KCYC01, PAC2KCYC01A

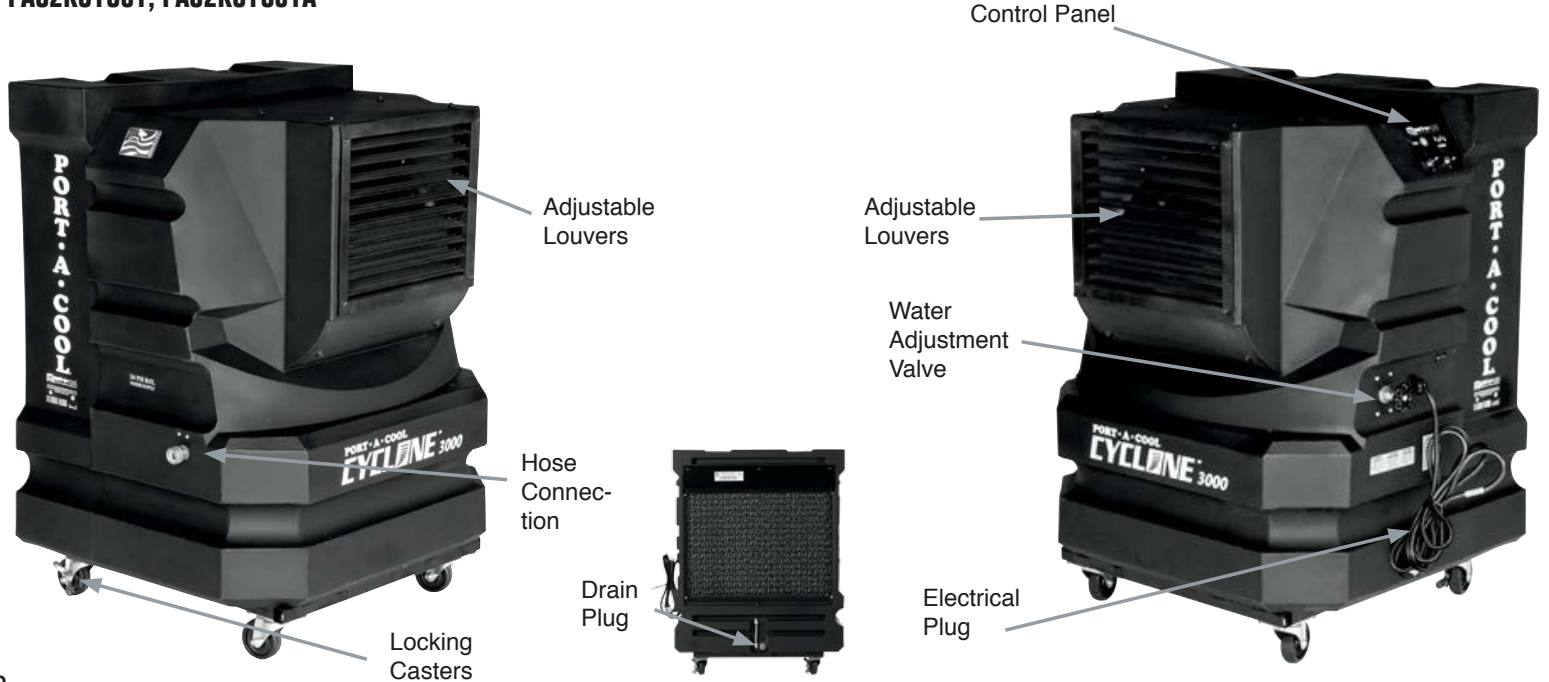

CYCLONE 3200 OVERVIEW

PACCYC04, PACCYC04A



Adjustable Louvers

Hose Connection

Locking Casters

Control Panel

Adjustable Louvers

Water Adjustment Valve

Electrical Plug

Drain Plug



CYCLONE 2000 OVERVIEW

PACCYC02, PACCYC02A



CYCLONE 2200 OVERVIEW

PACCYC03, PACCYC03A

Control Panel

Adjustable Louvers

Electrical Plug

Locking Casters

Adjustable Louvers

Water Adjustment Valve

Hose Connection

Drain Plug

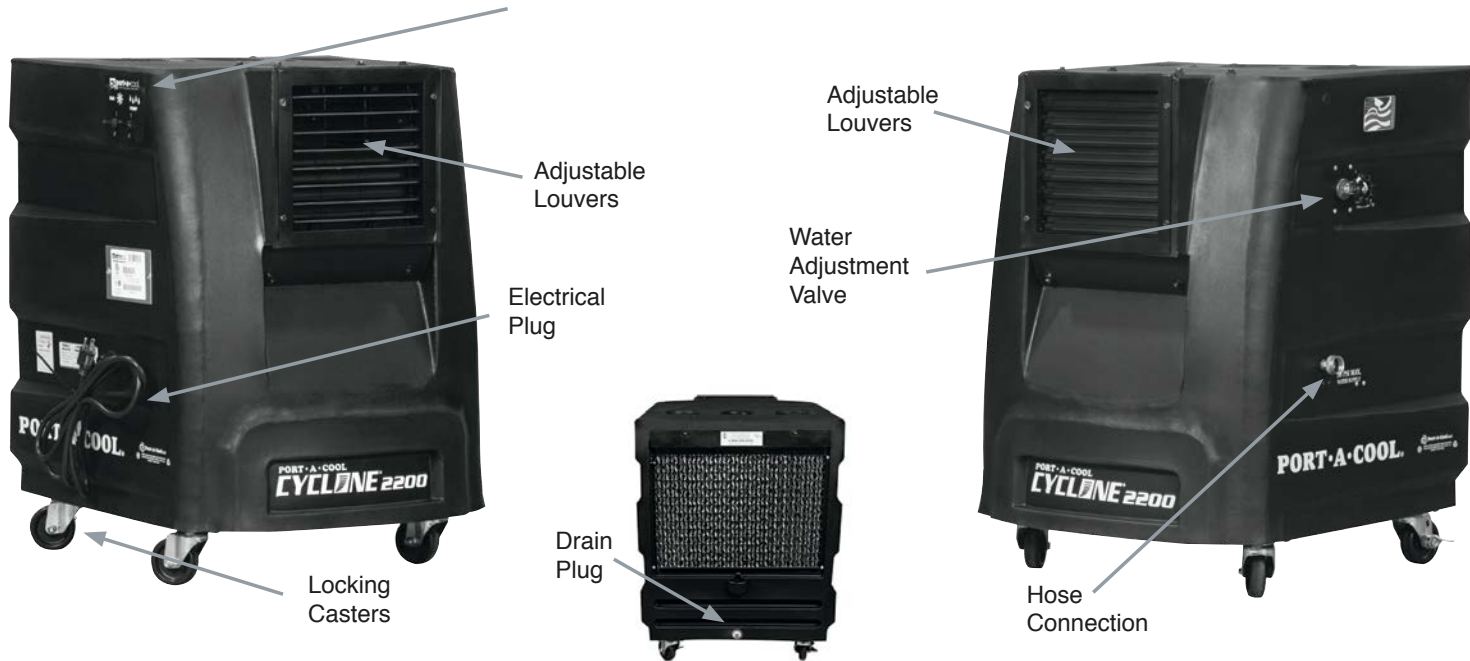

CYCLONE 1000 OVERVIEW

PAGCYC06

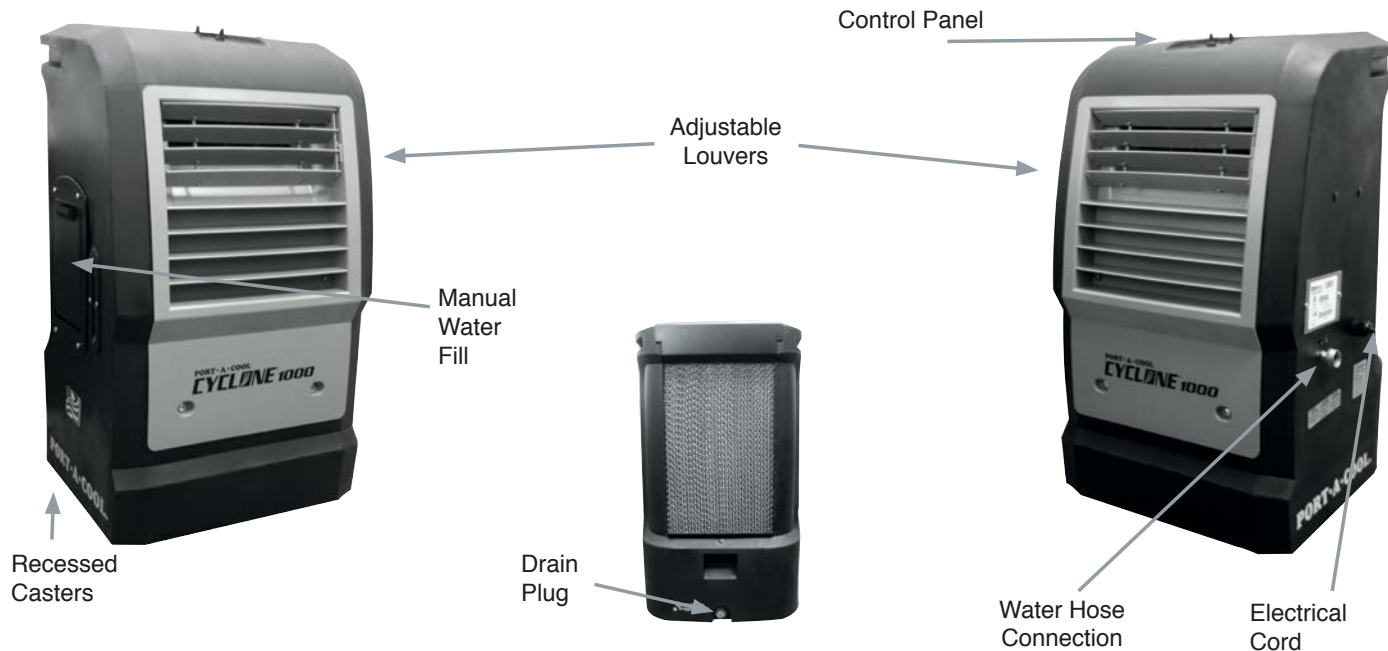

SAFETY INFORMATION

OPERATION WARNINGS

- 1) Not intended for use by children
- 2) Not intended for use by persons with reduced physical, sensory, or mental capabilities
- 3) Not intended for use by persons with lack of experience and knowledge, unless they have been given instruction and are supervised during operation
- 4) Children should be supervised to ensure they do not play with the appliance

SAFE OPERATION

To reduce the risk of electric shock, fire, or injury:

- Do not operate any product with a damaged cord or plug. Discard product or return to place of purchase for examination and/or repair.
- Do not run cord under carpeting. Do not cover cord with throw rugs, runners, or similar coverings. Arrange cord away from traffic area so it will not be tripped over.
- Read instructions and labels carefully.
- Always unplug the electric cord to the Portacool evaporative cooler before performing inspections or repairs.
- Plug into three-prong grounded GFCI protected electrical receptacle only.
- Do not step on or roll over power cord with heavy or sharp objects.
- Do not operate evaporative cooler unless all pads are securely in place.
- Remove the plug from the electrical receptacle by pulling on the plug and not the cord.
- Test the GFCI receptacle or breaker monthly to ensure it is functioning properly.
- Do not operate near open containers of flammable liquids or gases.
- Ensure evaporative cooler pumps are running continuously to saturate and wet combustible media when used in close proximity to open flame or spark producing activities. A distance of at least 35 feet away from open flame or sparks is recommended to ensure safe operation.
- Never wash the evaporative cooler cabinet with a garden hose; water may harm the motor and electrical system.
- If the product is damaged or malfunctions, do not continue to operate it. Refer to the warranty, troubleshooting or FAQ section, call Portacool, LLC, Technical Support at 1-888-266-5243, or email support@portacool.com.

GENERAL OPERATION

Electrical Connection

PRODUCT MUST BE IN UPRIGHT POSITION WITH COOLING PADS INSTALLED!

All models utilize a single power cord and control switches. Before connecting the plug to an outlet, ensure there is no standing water where the cord may lie or where the operator is standing. The use of separate multiple outlet devices is not recommended. When making electrical connections, ensure compliance to local and national codes. Use only with GFCI Protected Receptacles. Please refer to the Barcode Product Label on the side of the product for specific electrical requirements.

OPERATING PROCEDURES

Specifications

Each Portacool evaporative cooler has its own set of operational specifications, sizes, weights, voltage frequency, current requirements, etc. Please ask for the specifications for your model from your distributor, check the serial number plate, or visit www.portacool.com for the specifications for your product.

Placement of the Portacool Evaporative Cooler

There are three primary considerations when deciding where to place the Portacool evaporative cooler.

- 1) Make sure there is a clear, unobstructed path to provide maximum airflow.
- 2) If the evaporative cooler is positioned on a raised platform, ensure the platform constructed for holding the product is stable, well constructed, and will not allow the product to tip over and that it allows for the full weight of the evaporative cooler including water in the tank. The product must be level and in the upright position.

3) If placed near a wall or other obstruction, position the product a minimum of 3 feet (0.9 meters) from the wall or obstruction with pads facing the wall. This allows the unrestricted flow of warm air to the cooling pad side of the product. When using multiple products in close proximity, be sure to aim the product so the air flows complement each other to achieve maximum cooling capacity.

Starting the Pump and Adjusting the Water Flow

Once the water tank is full, moving the pump switch to the “ON” position will turn on the pump. When initially turning on the pump, the level in the water tank will drop suddenly and restart the flow of supply water. This is a normal condition, as the cooling pads require a large amount of water for proper wetting.

When the Portacool evaporative cooler is new, the new pads will require an initial ‘breaking-in’ period. This period is required for the pads to begin readily absorbing water. It may require up to a week to achieve maximum efficiency.

It is important to ensure that the spray bar is properly adjusted when first starting the water flow in the Portacool evaporative cooler. Increasing the flow using the water flow valve (see Quick Setup on page 2) makes this adjustment. Proper water adjustment should leave the pads saturated with water, but not flooded. Pads should appear wet. However, cascading amounts of water can actually reduce cooling efficiency. Proper adjustment will prevent problems and increase cooling capacity. When properly adjusted, one or two dry streaks will appear across the pads.

When turning the evaporative cooler off at the end of the day or week, the pump should be turned off about 15 minutes before the fan to allow the cooling pads to dry. This will increase the life of the pads.

Starting the Portacool Evaporative Cooler

COOLING PADS MUST BE INSTALLED AND CASTER LOCKS MUST BE ENGAGED

Start the fan by turning the fan switch to the ‘ON’ position. Step slowly through the speeds allowing the fan to obtain its full speed at the LOW speed before going to HIGH.

MAINTENANCE & STORAGE

MAINTENANCE

- 1) Keep the product clean to ensure peak operating performance.
- 2) The rugged, corrosion-resistant construction ensures low maintenance will be required. However, in dusty or dirty environments, optional filters are available from your distributor or at www.portacoolparts.com.

Daily Maintenance

The pump should be turned off approximately 15 minutes before the fan is turned off. This will allow the cooling pads to dry out and extend their life. This also helps control the growth of mildew, mold, bacteria, and other odor-causing elements.

Weekly Maintenance

The product should be shut down and the water tank should be drained once a week. Closing the water flow valve and removing the drain plug will accomplish this. Once the water tank is drained and the power disconnected, the pads may be removed to allow cleaning of the water tank. Dust may collect in the water tank over time. Replace pads in correct airflow direction, referring to the label on the pads.

Storage

- 1) Drain all water from the water tank and wipe clean, ensuring the pads and water tank are completely dry.
- 2) Roll up the electrical power cord and secure it to ensure it will not be rolled over, tripped over, or caught in equipment.
- 3) Cover the product completely to prevent dust build-up and store in a dry area. This also helps to prevent damage to the pads. Optional dust covers are available from your distributor or at www.portacoolparts.com.

The pump should be turned off approximately 15 minutes before the fan is turned off. This will allow the cooling pads to dry out and extend their life. This also helps control the growth of mildew, mold, bacteria, and other odor-causing elements.

TROUBLESHOOTING

The Portacool evaporative cooler consists of three systems — the fan system, the electrical system, and the water system. It is important to determine with which of the systems the problem is associated. Certain problems may be associated with more than one system. A careful check of all systems should be made to fully understand the extent of the problem.

CAUTION — DISCONNECT POWER BEFORE REMOVING COOLING PADS FROM THE PRODUCT!

NOTICE — POWER CORD MAY BE REPLACED ONLY BY THE MANUFACTURER OR QUALIFIED AGENT!

Repair and Replacement Procedures

Ensure all water is removed from the Portacool evaporative cooler and all power is disconnected. Remove all impediments to access the component you are checking or replacing.

REPLACING THE COOLING MEDIA PADS

The flap must be removed to allow access to the cooling pads. Start with the center pad, which can be tilted out from the top and lifted out of the drain trough. The two pads to either side of the center pad may then be removed in the same manner. To remove the two outside pads, they must first be pulled sideways toward the center of the Portacool evaporative cooler until they clear the side retainer before removing in the same manner as the other pads.

- 1) Locate the screw in the rear of the unit on the upper right side of the pad flap.
- 2) Remove screw and lower pad flap to vertical position.
- 3) Once the pad flap is moved, grasp the middle pad and tilt out at a 90 degree angle.
- 4) Pull the pad up to remove from unit. Repeat for other pads.

The following troubleshooting guide is intended to address the most common symptoms which may occur. If you are unable to resolve the issue, please call Technical Support. Turn off all power to the cooler before attempting to troubleshoot any of the following symptoms.

SYMPTOM	POSSIBLE CAUSES	REMEDY
Product fails to start or deliver air	<ol style="list-style-type: none">1. No electrical power to product<ol style="list-style-type: none">A. Circuit breaker trippedB. GFCI trippedC. Cord(s) unplugged or damaged2. Motor overheated and/or frozen	<ol style="list-style-type: none">1. Check power<ol style="list-style-type: none">A. Reset breaker*B. Reset GFCI*C. Plug in cord(s) or replace if damaged* If condition persists, call electrician2. Replace motor
Product starts but air delivery inadequate	<ol style="list-style-type: none">1. Insufficient air exhaust2. Insufficient water – pad not wet<ol style="list-style-type: none">A. Cooling pads pluggedB. Dry streaks on padsC. Large dry spots on padsD. Pump not workingE. Loose water connections	<ol style="list-style-type: none">1. Open windows or doors2. Check water distribution system<ol style="list-style-type: none">A. Clean or replace padsB. Check water levelC. Make sure cooler is level, clean spray barD. Clean or replace pumpE. Check for leaks and correct
Water draining from cooler	<ol style="list-style-type: none">1. Float arm improperly adjusted2. Seat in float valve leaking3. Drain bushing/cap not tight	<ol style="list-style-type: none">1. Adjust float to proper level2. Replace float valve3. Tighten fitting and/or cap
Musty or unpleasant odor	<ol style="list-style-type: none">1. Stale or stagnant water in sump2. Pads mildewed or clogged3. Pads not completely wet before cooler is turned on	<ol style="list-style-type: none">1. Drain, flush and clean sump2. Replace pads3. Turn on pump before starting fan
Knocking, shaking, or rattling sounds	<ol style="list-style-type: none">1. Loose parts2. Blower wheel loose or rubbing	<ol style="list-style-type: none">1. Check and tighten where needed2. Inspect and adjust, or replace
Water droplets in the discharge air stream	<ol style="list-style-type: none">1. Too much water delivered to the cooling pads2. Outdoor humidity level is too high or it is raining3. Leaking hose	<ol style="list-style-type: none">1. Make sure pads are properly positioned in the frames and product is level2. Use cooler as a fan only (turn pump off) or discontinue use of product until outdoor humidity level drops.3. Tighten connection or replace hose

TECHNICAL SUPPORT

TECHNICAL SUPPORT

Technical support and service is available directly from your distributor or call Portacool, LLC Technical Support Hot Line at 888-266-5243 for the distributor nearest you. You may also contact the Support Hot Line for consultation on troubleshooting and parts replacement.

Please have serial number and model number of product available.

WARRANTY AND REPLACEMENT PARTS

PORTACOOOL® Evaporative Cooler Limited Warranty

For one (1) year from date of purchase, Portacool, LLC (hereafter "Portacool") warrants any original component part or parts of its Portacool™ portable evaporative coolers (the "Equipment") that are found, upon examination by factory-authorized personnel, to be defective in material or workmanship, excepting, however, that the following component motors shall be warranted by Portacool for a period of three (3) years from the date of purchase: MOTOR-013-04, MOTOR-010-07, MOTOR-012-06, MOTOR-012-05 and MOTOR-034-01.

All transportation charges for shipment of the Equipment and/or its component parts that are submitted for replacement or repair under this warranty must be borne by the purchaser.

If the Equipment and/or its original component parts develop a defect covered by this limited warranty within the applicable time periods described above, the same will be repaired or replaced at Portacool's option. In the case of a breach of any implied or written warranty relating to the Equipment and/or its component parts, Portacool shall not be liable for any incidental or consequential damages, and the limits of liability against Portacool for any such breach shall not exceed the cost of replacement or repair of the Equipment.

This warranty is void if the Equipment and/or its component parts are found to have been misused, abused, repaired by or tampered with by unauthorized or unqualified personnel.

RETURNS

Returned Merchandise Authorization (RMA) Procedures

All Portacool evaporative coolers, parts, or materials being returned to Portacool, LLC for warranty replacement or repair require an RMA (Return Merchandise Authorization) number.

Warranty parts can be replaced by:

1. The distributor can purchase the part with an RMA number and will only be charged for the cost of the part, not for the shipping. When the defective part is returned freight paid, the distributor's account will be credited for the cost of the part.
2. The defective part need to be returned to Portacool, LLC, labeled with the RMA number within 90 days of receipt of replacement parts.
3. The customer / distributor can call Tech Support to get an RMA number to send the defective part back to Portacool, LLC. Once the part is received by Portacool, a replacement part will be sent at no charge.

Information needed to get an RMA number:

1. The product serial number or manufacturer date code
2. The product model number (ex. PAC2K363S)
3. The part number or description of the part to be replaced

Only major component parts need an RMA number, i.e. fans, motors, pumps, and some plumbing parts. For replacement of small parts, the serial and model numbers are still required, but the parts do not need to be returned to Portacool, LLC.

For warranty replacement parts call Portacool® Technical Support at 1-888-266-5243. FAX: 936-598-1431.

Shipping Address
Portacool, LLC
721 FM 2468
Center, Texas 75935

Mailing Address:
Portacool, LLC
P.O. Box 2167
Center, Texas 75935

To expedite your request, please submit the RMA form found on our website at info.portacool.com/returnshold

CYCLONE 1000 PARTS

PACCYC06

PACCYC06

Revised 02/24/15

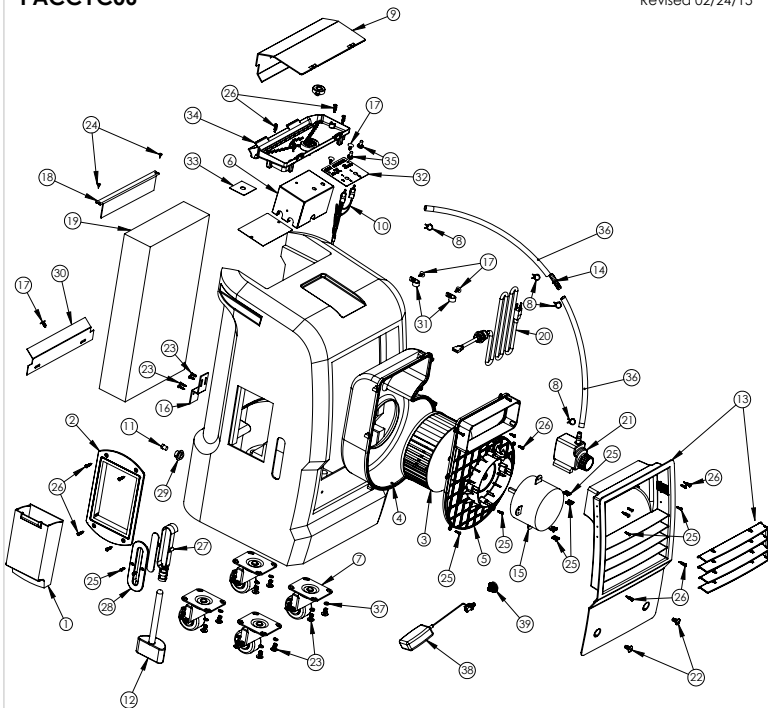

ITEM	PART #	DESCRIPTION	ITEM	PART #	DESCRIPTION
1	ACCD00R-C1-714	WATER FILL DOOR	22	PUMP-CYC-3	CYCLONE PUMP - DK4000
2	ACCFRM-C1-715	FILL DOOR FRAME	23	S-003	5/16 - 18 x 1/2" TRUSS HEAD SCREW (2EA)
3	BLOWER-WHL-2CW	CYCLONE 2000 BLOWER WHEEL - CW	24	S-007	5/16 - 18 x 3/4 TRUSS HEAD SCREW (16EA)
4	BLWHS6-C1-7162	BLOWER HOUSING	25	S-011	#8 x 9/16" WASHER HEAD SCREW
5	BLWRCVR-C1-7163	BLOWER HOUSING COVER	26	S-818-58PPH	8 - 18 x 5/8 PAN HEAD SCREW (24EA)
6	BDX-UL-02	1 & 2 SPEED ELECTRICAL BOX	27	S-1016-1PPH	10-16x1 PHILLIPS SELF-TAP SCREW (12EA)
7	CASTER-3-NL	3" NON-LOCKING CASTER	28	SGTFRM-C1-711	SIGHT GLASS FRAME FOR CYCLONE1000
8	CLAMP-01	1/2" WIRE TUBING CLAMP	29	SGTGLS-C1-719	SIGHT GLASS W/EXTERNAL FRAME
9	COVER-C1-716	TOP TRAY COVER, CYCLONE1000	30	SPIN-FTG-02	1/4" SPIN FITTING FOR 16" UNIT
10	CTRL-2SPD-01	2-SPEED SWITCH SET	31	SPLASHGUARD-C1	SPLASH GUARD CYCLONE1000
11	CYCLONE-H-10	CYCLONE 1000 HOUSING (BLACK)	32	SPRAY-ACC-01	#012 NYLON CLIP
12	DRAIN-PLUG-01	1/4" NPT PLUG #P-28	33	SWITCHPL-2SPD-T	SWITCH COVER PLATE - 2SPD(TPI)
13	FLOAT-CYC-717	FLOAT FOR CYCLONE1000	34	TRAY-ACC-C1	BOTTOM DRIP TRAY CAP/COVER
14	FRNTPNL-C1-7112	FRONT PANEL, WITH LOUVERS	35	TRAY-C1-713	DRIP TRAY WITH CAP/VALVE
15	HOSE-FTG-09	1/2" BARB FLOW RESTRICTOR	36	TOG-BOOT-01	BLK RUBBER TOGGLE-SWITCH BOOT
16	MOTOR-017-01	CYCLONE 1000 2-SPEED MOTOR (B-0)	37	TUBE-01	1/2" ID SFT PLASTIC TUBE
17	MTR-BRKT-C1	BLOWER HOUSING SUPPORT BRACKET	38	WASHER-04	5/16 LOCK WASHER
18	MWC-ACC-02	CHRISTMAS TREE FASTENER (5EA)	39	FLOAT-CYC-03	FLOAT VALVE FOR CYCLONE UNITS
19	PAD-BRACKET-C1	PAD RETENTION BRACKET	40	PAC-PLB-01	INLET HOSE ADAPTER
20	PADM4022/G	4"x12"x22" MICROFLUTE 45/46			
21	POWERCORD-02F	10" POWER CORD WITH BRASS NUT/WASHER			

CYCLONE 3000 PARTS

PAC2KCYC01 PAC2KCYC01A

REVISED 02/16/2015

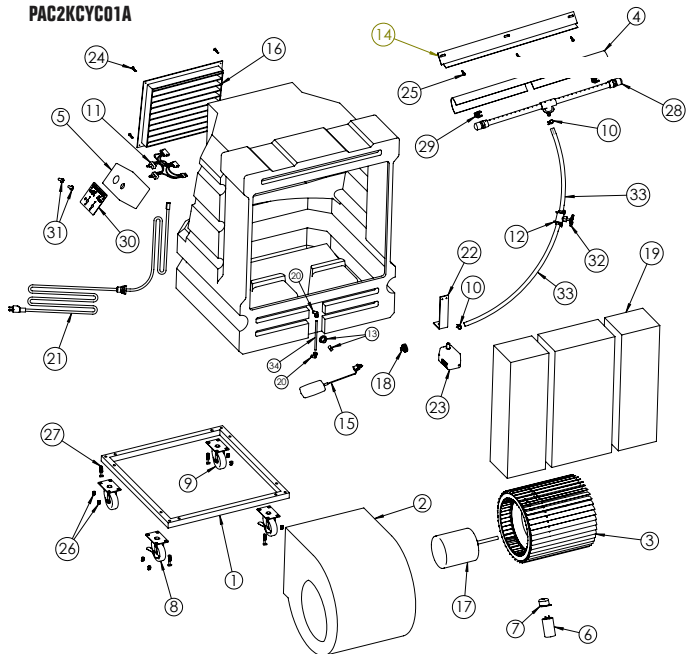

ITEM	PART #	DESCRIPTION	ITEM	PART #	DESCRIPTION
1	BASE-CYCLONE	CADDY FRAME	18	PAC-PLB-01	INLET HOSE ADAPTER
2	BLOWER-01	BLOWER HOUSING	19	PAD6022.5/26	KUUL PAD SET FOR CYCLONE
3	BLOWER-WHL-01	BLOWER WHEEL	20	POLY-FTG-06	90 DEG. FITTING FOR SIGHT TUBE
4	BONNET-05	BONNET	21	POWERCORD-02F	10ft POWER CORD W / DOME STRAIN RELIEF
5	BOX-UL-02	2 SPD UL ELECTRICAL BOX	22	PUMP-BRACKET-#4	ALUM. BAR PUMP BRACKET
6	CAPACITOR-01	PSU 25-30 CAPACITOR	23	PUMP-CYC-3	CYCLONE PUMP - DK400
7	CAPBOOT-01	WATER PROOF BOOT FOR CAPACITOR	24	S-006	TEC SCREW S006
8	CASTER-3-L	3" LOCKING CASTERS	25	S-009	10/24 x 3/3 TRUSS HEAD SCREW
9	CASTER-3-NL	3" CASTERS	26	S-014	5/16 x 1" TRUSS HEAD SCREW
10	CLAMP-01	1/2" WIRE SPRING CLAMP	27	S-017	5/16 - 18 x 1.5" TRUSS HEAD SCREW
11	CTRL-2SPD-01	2-SPEED SWITCH ASSEMBLY	28	SPRAY-CYC-01	16" SPRAY BAR
12	CTRL-VLV-BRKT-1	VALVE-01 MOUNTING BRACKETS	29	SPRAY-ACC-04	SPRAY BAR CLIP
13	DRAIN-PLUG-01	DRAIN PLUG	30	SWITCHPL-2SPD	2 SPEED SWITCH PLATE
14	FLAP-05	FLAP	31	TOG-BOOT-01	RUBBER TOGGLE SWITCH BOOT (2)
15	FLOAT-CYC-03	FLOAT VALVE FOR CYCLONE UNITS	32	VALVE-01	PUMP TO SPRAY BAR CONTROL VALVE
16	LOUVERS-CYC-16	CYCLONE 3000 LOUVER W/MESH	33	TUBE-01	PUMP TO SPRAY BAR TUBING
17	MOTOR-013-07	1/3 HP - 2SPD MOTOR	34	TUBE-03	SIGHT TUBE

CYCLONE 2000 PARTS

PACCYC02

PACCYC02A

Revised 02/04/2015

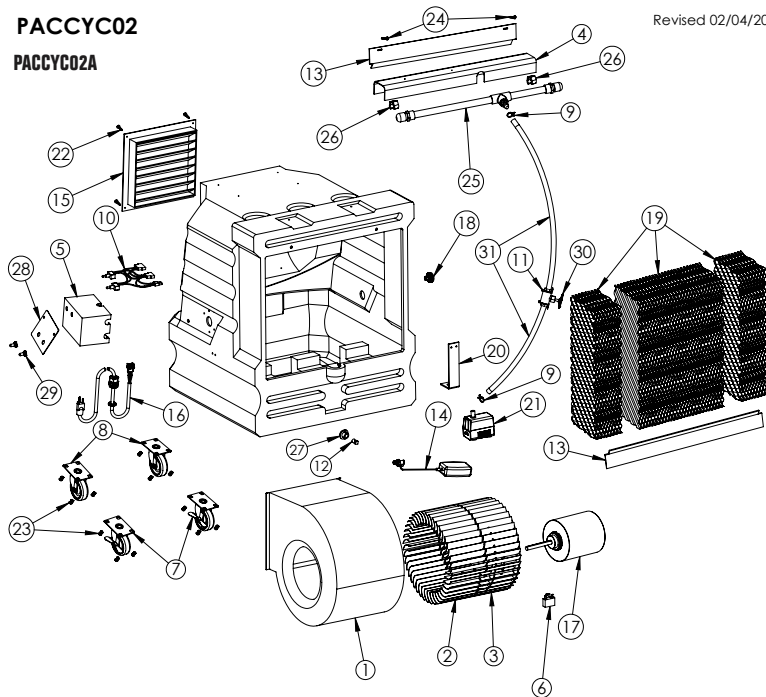

ITEM	PART #	DESCRIPTION	ITEM	PART #	DESCRIPTION
1	BLOWER-02	BLOWER HOUSING - CYCLONE2000	17	MOTOR-016-01	CYCLONE2000 - 2SPD MOTOR
2	BLOWER-WHL-2CW	CYCLONE2000 BLOWER WHEEL (PART 1)	18	PAC-PLB-14	INLET HOSE ADAPTER
3	BLOWER-WHL-3CCW	CYCLONE2000 BLOWER WHEEL (PART 2)	19	PAD6019/22	KUUL PAD SET FOR CYCLONE2000
4	BONNET-06	22.5" EXTRUDED BONNET-CYCLONE2000	20	PUMP-BRACKET-5	PUMP MOUNT BRACKET
5	BOX-UL-02	1 & 2 SPD UL ELECTRICAL BOX	21	PUMP-CYC-3	CYCLONE PUMP - 0K400
6	CAPACITOR-04	RUN CAPACITOR FOR CYCLONE2000	22	S-002	TEC SCREW S006
7	CASTER-3-L	3" LOCKING CASTERS	23	S-007	10/24 x 3/3 TRUSS HEAD SCREW
8	CASTER-3-ML	3" CASTERS	24	S-011	5/16 x 1" TRUSS HEAD SCREW
9	CLAMP-01	1/2" WIRE SPRING CLAMP	25	SPRAY-CYC-02	SPRAY BAR
10	CTRL-2SPD-01	2-SPEED SWITCH ASSEMBLY	26	SPRAY-ACC-01	SPRAY BAR CLIP
11	CTRL-VLV-BRKT	VALVE-01 MOUNTING BRACKETS	27	SPIN-FTG-02	SPIN FITTING FOR 16" UNIT
12	DRAIN-PLUG-01	DRAIN PLUG	28	SWITCHPL-2SPD	2 SPEED SWITCH PLATE
13	FLAP-CYC-2	FLAP/SPLASHGUARD-CYCLONE2000	29	TGG-BOOT-01	RUBBER TOGGLE SWITCH BOOT (2)
14	FLOAT-CYC-03	FLOAT VALVE	30	VALVE-01	PUMP TO SPRAY BAR CONTROL VALVE
15	LOUVERS-CYC-11	LOUVER W/ MESH - CYCLONE2000	31	TUBE-01	PUMP TO SPRAY BAR TUBING
16	POWERCORD-02F	10ft POWER CORD W / DOME STRAIN RELIEF			

CYCLONE 2200 PARTS

PACCYC03
PACCYC03A

Revised 02/25/15

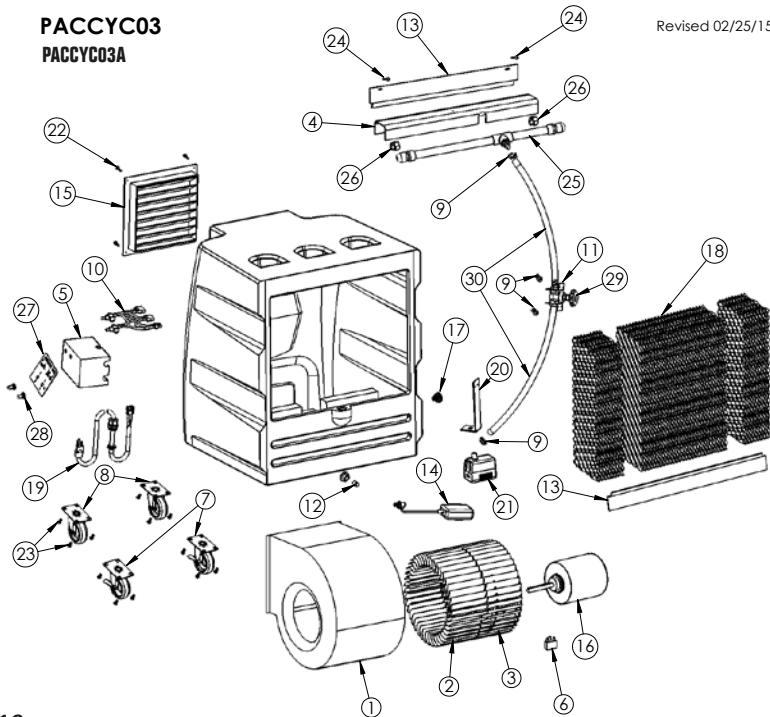

ITEM #	PART #	DESCRIPTION	ITEM #	PART #	DESCRIPTION
1	BLOWER-02	BLOWER HOUSING - CYCLONE2000	16	MOTOR-016-01	CYCLONE2000 - 2SPD MOTOR
2	BLOWER-WHL-2CW	CYCLONE2000 BLOWER WHEEL (PART 1)	17	PAC-PLB-14	INLET HOSE ADAPTER for CYCLONE2000
3	BLOWER-WHL-3CCW	CYCLONE2000 BLOWER WHEEL (PART 2)	18	PADG019/22	KUUL PAD SET FOR CYCLONE2200
4	BONNET-06	22.5" EXTRUDED BONNET-CYCLONE2000	19	POWERCORD-02F	10ft POWER CORD W / DOME STRAIN RELIEF
5	BDX-UL-02	1 & 2 SPD UL ELECTRICAL BOX	20	PUMP-BRACKET-6	PUMP MOUNT BRACKET-CYCLONE2000
6	CAPACITOR-04	RUN CAPACITOR FOR CYCLONE2000	21	PUMP-CYC-3	CYCLONE PUMP - DK400
7	CASTER-3-L	3" LOCKING CASTERS	22	S-002	#8 x 3/4" TEK SCREW
8	CASTER-3-NL	3" CASTERS	23	S-007	5/16 -18 x 3/4 TRUSS HEAD SCREW
9	CLAMP-01	1/2" WIRE SPRING CLAMP	24	S-011	#8 x 9/16" WASHER HEAD SCREW
10	CTRL-2SPD-01	2-SPEED SWITCH ASSEMBLY	25	SPRAY-CYC-02	SPRAY BAR FOR CYCLONE2000
11	CTRL-VLV-BRKT	VALVE-01 MOUNTING BRACKETS	26	SPRAY-ACC-01	SPRAY BAR CLIP
12	DRAIN-PLUG-01	DRAIN PLUG	27	SWITCHPL-2SPD-T	2 SPEED SWITCH PLATE
13	FLAP-CYC-2	FLAP/SPLASHGUARD-CYCLONE2000	28	TOG-BOOT-01	RUBBER TOGGLE SWITCH BOOT (2)
14	FLOAT-CYC-03	FLOAT VALVE	29	VALVE-01	PUMP TO SPRAY BAR CONTROL VALVE
15	LOUVERS-CYC-11	LOUVER W/ MESH - CYCLONE2000	30	TUBE-01	PUMP TO SPRAY BAR TUBING

CYCLONE 3200 PARTS

PACCYC04
PACCYC04A

Revised 02/25/15

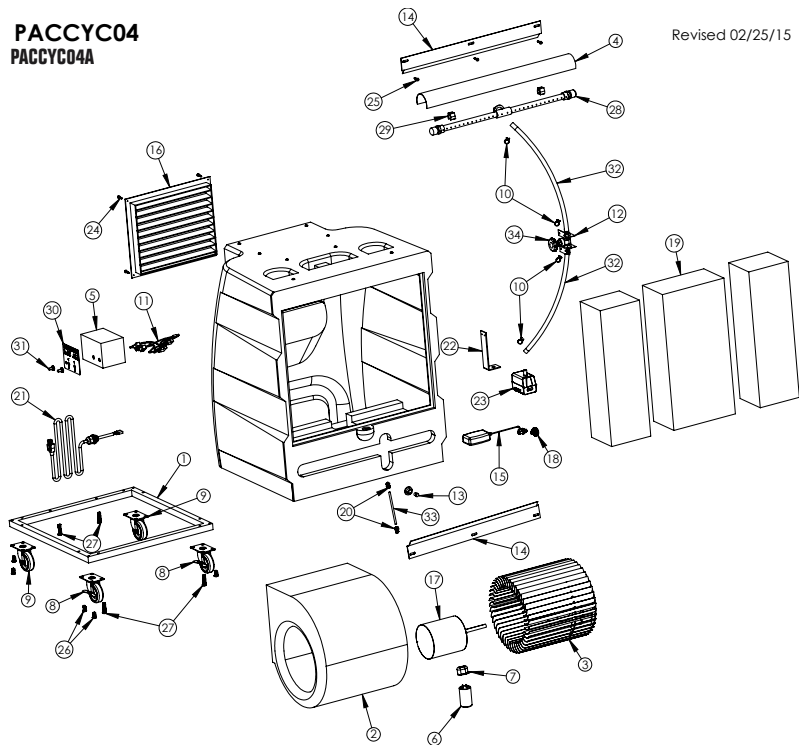

ITEM	PART #	DESCRIPTION	ITEM	PART #	DESCRIPTION
1	BASE-CYCLONE	CADDY FRAME	18	PAC-PLB-14	INLET HOSE ADAPTER
2	BLOWER-01	BLOWER HOUSING	19	PAD6022.5/26	8"x12"x22" KUUL PAD FOR CYCLONE
3	BLOWER-WHL-01	BLOWER WHEEL	20	POLY-FTG-06	90 DEG. FITTING FOR SIGHT TUBE
4	BONNET-05	BONNET	21	POWERCORD-02F	10ft POWER CORD W / DOME STRAIN RELIEF
5	BDX-UL-02	2 SPD UL ELECTRICAL BOX	22	PUMP-BRACKET-#4	ALUM. BAR PUMP BRACKET
6	CAPACITOR-01	PSU 25-30 CAPACITOR	23	PUMP-CYC-3	CYCLONE PUMP - 0K400
7	CAPBOOT-01	WATER PROOF BOOT FOR CAPACITOR	24	S-006	TEC SCREW S006
8	CASTER-3-L	3" LOCKING CASTERS	25	S-009	10/24 x 3/3 TRUSS HEAD SCREW
9	CASTER-3-NL	3" CASTERS	26	S-014	5/16 x 1" TRUSS HEAD SCREW
10	CLAMP-01	1/2" WIRE SPRING CLAMP	27	S-017	5/16 - 18 x 1.5" TRUSS HEAD SCREW
11	CTRL-ZSPD-01	2-SPEED SWITCH ASSEMBLY	28	SPRAY-CYC-01	16" SPRAY BAR
12	CTRL-VLV-BRKT-1	VALVE-01 MOUNTING BRACKETS	29	SPRAY-ACC-04	SPRAY BAR CLIP
13	DRAIN-PLUG-01	DRAIN PLUG	30	SWITCHPL-2SPD	2 SPEED SWITCH PLATE
14	FLAP-05	FLAP	31	TOG-BOOT-01	RUBBER TOGGLE SWITCH BOOT [2]
15	FLOAT-CYC-03	FLOAT VALVE FOR CYCLONE UNITS	32	TUBE-01	PUMP TO SPRAY BAR TUBING
16	LOUVERS-CYC-16	CYCLONE 3000 LOUVER W/MESH	33	TUBE-03	SIGHT TUBE
17	MOTOR-013-07B	1/3 HP - 2SPD MOTOR (B0)	34	VALVE-01	PUMP TO SPRAY BAR CONTROL VALVE

WIRING DIAGRAM

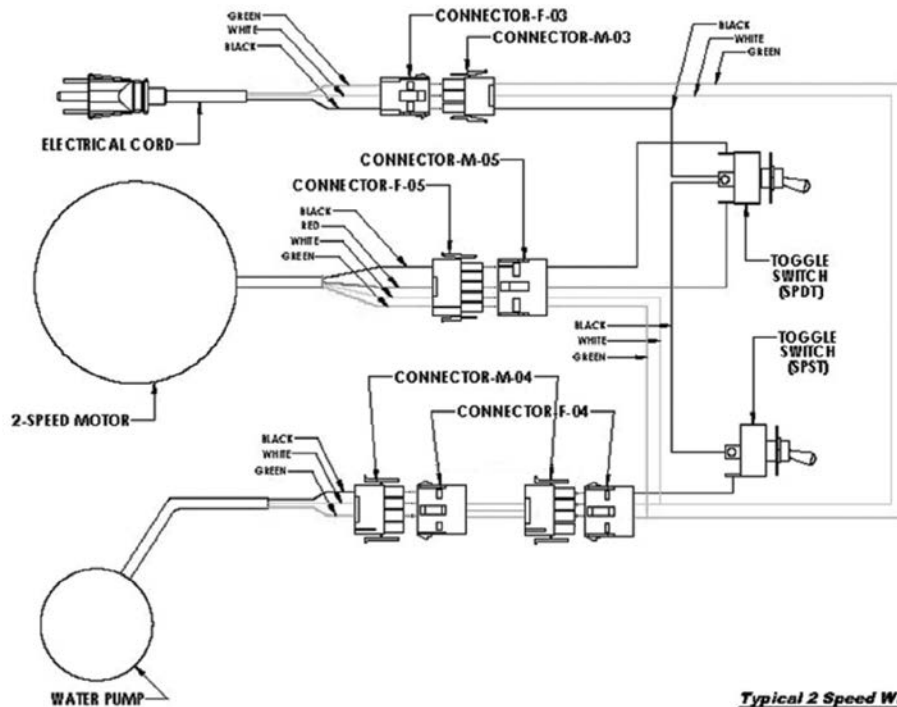

Typical 2 Speed Wiring

FREQUENTLY ASKED QUESTIONS

Q. WHAT ASSEMBLY IS REQUIRED?

A. None. Portacool Cyclone units are ready to use right out of the box.

Q. HOW DO I PREPARE MY PORTACOOOL PRODUCT FOR STORAGE?

A. Drain the product, dry out the pads, cover the product, and store in a dry place.

Q. I JUST RAN THE COOLER FOR THE FIRST TIME AND THERE'S AN UNPLEASANT ODOR!

A. The pads, located in the back of your Portacool product, have never been wet before. The resin in the pads will emit an odor the first time you wet them that lasts approximately one to three weeks. Keep the product in an open area until the odor goes away or put a capful of laundry softener directly in the tank in the bottom of your product. After approximately two weeks of operation, the odor should disappear.

Q. MY PORTACOOOL PRODUCT ISN'T PUTTING OUT ANY COOL AIR.

A. First, make sure the water source and electricity source are connected and working. Second, check to see if the pads are damp. If not, adjust the water flow with the water adjustment valve. Third, make sure there is water in the tank. It should be allowed to fill before you turn the pump on.

Q. WHAT IS THE BEST ENVIRONMENT TO PRODUCE THE MOST COOL AIR?

A. For optimum performance, the temperature should be 85° F or higher and the relative humidity should be below 75%. However, Portacool products will reduce the temperature in almost any environment, making it more pleasant.

Q. HOW OFTEN DO PADS HAVE TO BE REPLACED?

A. Depending on the quality of maintenance and frequency of use, pads typically last up to five years.

Q. WHAT IS THE DIFFERENCE BETWEEN EVAPORATIVE COOLING AND

MISTING SYSTEMS?

A. Misting units spray a shower of water into the air that will collect on people, objects, equipment, floors, etc. Portacool products use the process of evaporation to produce cooler air, but do not discharge a mist.

Q. WHERE CAN I BUY REPLACEMENT PARTS?

A. Replacement parts may be purchased from any Portacool product distributor or directly from Portacool Parts/Technical Support department. You may also visit www.portacoolparts.com to order online.

Q. WHAT IS THE AMOUNT OF MOISTURE PRODUCED?

A. An increase in humidity of approximately two to five percent is produced, depending on the temperature and humidity of the environment. This increase is not noticeable in a ventilated area where the air produced by the unit is exhausted.

Q. HOW LONG WILL THE WATER SUPPLY LAST IN THE TANK?

A. With no direct water source available, the water will evaporate in a filled water tank within two to 10 hours of operation, depending on the water capacity of the product, ambient conditions, temperature, and humidity. A water source for refilling the tank is recommended by the manufacturer.

Q. WHERE ARE THE MODEL AND SERIAL NUMBERS FOUND?

A. The model number can be found on a metal plate on the outside of the product. Model numbers begin with the letters "PAC." Serial numbers are all-digits.

Q. WHAT IF MY QUESTIONS AREN'T ANSWERED HERE?

A. Our Tech Support staff is available 8 a.m. to 5 p.m. Central Time, Monday through Friday at 1-888-COOL-AID or you can e-mail them at support@portacool.com.

PORTACOOOL™

WHEN COMFORT COUNTS™

CUSTOMER SERVICE CONTACT

1-936-598-5651 * 1-800-695-2942

ORDERS@PORTACOOOL.COM

TECHNICAL/PARTS CONTACT

1-936-598-5651 * 1-888-COOLAID

SUPPORT@PORTACOOOL.COM

VISIT PORTACOOOL.COM

OR CALL 1-936-598-5651

FOR MORE INFORMATION

The manual is available in other languages.

To download a digital copy, please visit
www.portacool.com.

El manual está disponible en otros idiomas.

Para descargar una copia digital, por favor
visite www.portacool.com.

Le manuel est disponible en d'autres langues.

Pour télécharger une copie numérique, se il
vous plaît visitez www.portacool.com.

والدليل هو متاح في اللغات الأخرى. لتحميل
نسخة رقمية، يرجى زيارة www.portacool.com

MANR0002

Portacool, LLC • Manufacturer of Portacool™ portable evaporative coolers and KÜÜL® Pads evaporative media
709 Southview Circle • Center, Texas 75935 • 936-598-5651 • www.portacool.com • www.kuulpads.com